

# 承认书

*SPECIFICATION FOR APPROVAL*

*Switching power Supply/开关电源*

客 户:

CUSTOMER: \_\_\_\_\_

产品描述:

DESCRIPTION: Input:100~240V AC 50/60Hz Output:12VDC1A

机种型号:

OUR MODEL NO: S-12-12

样品编号:

日期:

SAMPLE NO: S-12-12

DATE: 2011-05-16

产品颜色:

SAMPLE COLOR: Black

White

APPROVAL SIGNATURE/客户确认		
核准/APPROVED BY	审核/CHECKED BY	检测/TESTED BY

Manufacturer/制造商		
业务/SALES	核准/APPROVED BY	设计/DESIGNED BY
	黄	华

深圳市美乐唯科技有限公司

ShenZhen Mulview Technology Co., Limited

地址：深圳龙岗坂田文坑工业区 2 栋 2 楼西

Tel: 0086-755-28597802/0086-13927453792 Fax: +86-755-28597007

[Http://www.mtlcctv.com](http://www.mtlcctv.com)

1、描述/ DESCRIPTION:

本规格书适应于 S-12-12 型号的开关电源.

The purpose of the document is to specify the functional requirements of a 12W switching power supply.

2、输入特性/INPUT CHARACTERISTICS:

2.1 输入电压/Input Voltage:

额定电压/Rated Voltage:100~240Vac

调整范围/Variation Range:90-264Vac

2.2 输入频率/Input Frequency:

额定频率/ Rated Frequency: 50/60Hz.

调整频率/Variation Frequency:47-63Hz

2.3 输入电流/Input Current:

当输入交流电压为额定值的下限电压负载满载时,最大输入交流电流 0.35A.

0.35Amps max At any input voltage and rated, DC output rated load.

2.4 浪涌电流/Inrush Current:

当输出为额定负载,环境温度为 25℃,输入 240Vac 冷态起机时的最大浪涌电流小于 80A.

80 Amps Max. Cold start at 240Vac input, with rated load and 25℃ ambient.

2.5 AC 漏电流/Ac Leakage Current:

当输入电压 240Vac 时,最大漏电流为 0.25mA.

0.25mA Max.At240Vac input.

### 3、输出特性/OUTPUT CHARACTERISTICS:

#### 3.1 输出功率/Power output

电压 Voltage	最小负载 Min. Load	额定负载 Rated. Load	待机功耗 Standby power	输出功率 Output power
12Vdc	0.01A	1A	0.5W MAX	12W

#### 3.2 负载特性,调整率/Combined Load/Line Regulation

电压 Voltage	最小负载 Min. Load	额定负载 Rated. Load	线性调整 Line Regulation	负载调整 Load Regulation
12Vdc	0.01A	1A	±1%	±5%

#### 3.3 纹波和噪音 Ripple and Noise:

测试条件:在额定电压及额定负载条件下,使用示波器带宽为 20MHz 连接到充电器的输出端,同时输出端并联一个 47uF 的电容器和一个 0.1uF 的瓷片电容.

Under nominal voltage and nominal load,the ripple and noise are as follows when measure with Max.Bandwidth of 20MHz and Parallel 47uF/0.1uF,crossed connected at testing point.

电压 Voltage	最大纹波/最大噪音 Ripple and Noise(Max.)
<u>+12Vdc</u>	<u>120mV p-p</u>

#### 3.4 启动延迟时间/Turn on delay time:

当输入 115Vac 和输出最大负载时,最大启动时间为 3S.  
3Second Max.at 115Vac input and output Max.load.

#### 3.5 上升时间/Rise time:

当输入 115Vac 和输出最大负载时最大时间为 40 mS.  
40 mS Max.at 115Vac input and output Max load.

#### 3.6 保持时间/Hold up time:

当输入 115Vac 和输出最大负载时,最小保持时间为 5 mS .  
5 mS Min.at 115Vac input and output Max.Load.

#### 3.7 效率/Efficiency:

当 115/230Vac 输入电压时, 1/4, 1/2, 3/4 和满载计算平均效率, 最小 70%。

70% Min, At 115/230Vac input voltage,1/4, 1/2, 3/4 and full load calculation average efficiency.

#### 4、保护功能/PROTECTION FUNCTION:

##### 4.1 短路测试/Short circuit test:

该电源供给器在短路解除时能正常工作恢复.

The power supply will be auto recovered when short circuit faults remove.

##### 4.2 过流保护/Over current Protection:

过流故障排除后,电源将自动恢复正常工作.

The power supply will be auto recovered when over current faults remove.

##### 4.3 过压保护/Over Voltage Protection:

当输出电压超过额定电压的 120%~170%时,电源将保护,故障排除后能恢复正常工作.

The power supply will auto recovered when faults remove 120%~170%.

#### 5、环境要求/ENVIRONMENTAL REQUIREMET:

##### 5.1 工作温度/Operating Temperature:

0°C-40°C,满载,正常工作.

0°C to 40°C,Full load, Normal operation.

##### 5.2 储藏温度/Storage Temperature:-20°C to 80°C

带外壳/With package

##### 5.3 工作湿度/Relative Humidity:

5%(0°C)~90%(40°C),72 小时,满载,正常工作.

5%(0°C)~90%(40°C)RH,72Hrs,Full load, Normal operating.

##### 5.4 振动/Vibration:

###### 1. 测试标准:国际电工电子委员会

Operating: IEC 721-3-3 3M3

5~9Hz,A=1.5mm

加速度(9~200Hz,Acceleration 5m/S<sup>2</sup>)

###### 2. 运输/Transportation:

IEC 721-3-2 2M2

5-9Hz,A=3.5mm

9~200Hz,加速度 Acceleration=5m/S<sup>2</sup>

200~500Hz,加速度 Acceleration=15m/S<sup>2</sup>

3. 轴向振动/Axes,10 cycles per axis.

在测试过程中不能出现永久性的损坏.

No permanent damage may occur during testing.

在电源开启和关闭后,样机能够恢复到最初条件.

The SAMPLE has to restore to its original situation after power off/on..

5.5 跌落试验/Dropping Packed:

插墙式跌落高度为 1 米、桌面式跌落高度为 760mm ;

1M for wallmount type and 760mm for desktop type as above described.

测试台面是厚 13mm 的夹木板 , 离地面高 19-20mm

The horizontal surface consists of hardwood at least 13mm thick, mounted on two layers of plywood each 19mm to 20mm thick,all supported on a concrete or equivalent non-resilient floor.

6、安全要求/SAFETY REQUIREMENT:

6.1 安全:符合标准 CE

Safety: accord with CE

6.2 高压/DIELECTRIC STRENGTH Hi-Pot:

初级对次级/Primary to secondary:3000Vac10mA/3S for type test.

6.3 绝缘抗阻/ Insulation resistance:

初级对次级/Primary to secondary:10MΩ min at 500V DC.

6.4 EMI 标准/EMI STANDARD

Meets the Limits of/测试符合

<1>.EN55022 class B rules

7、 结构参数/MECHANICAL REQUIREMENT:

7.1 外壳/Enclosure:

外壳尺寸: L81 x W50 x H28.8mm;

The power supply size: L74 x W28 x H42mm;

7.2 输入线/Input Connector:

2Pin UL 插脚/Two pin input plug of UL (can be changed to UK 3pin input plug according to customer's requirement)

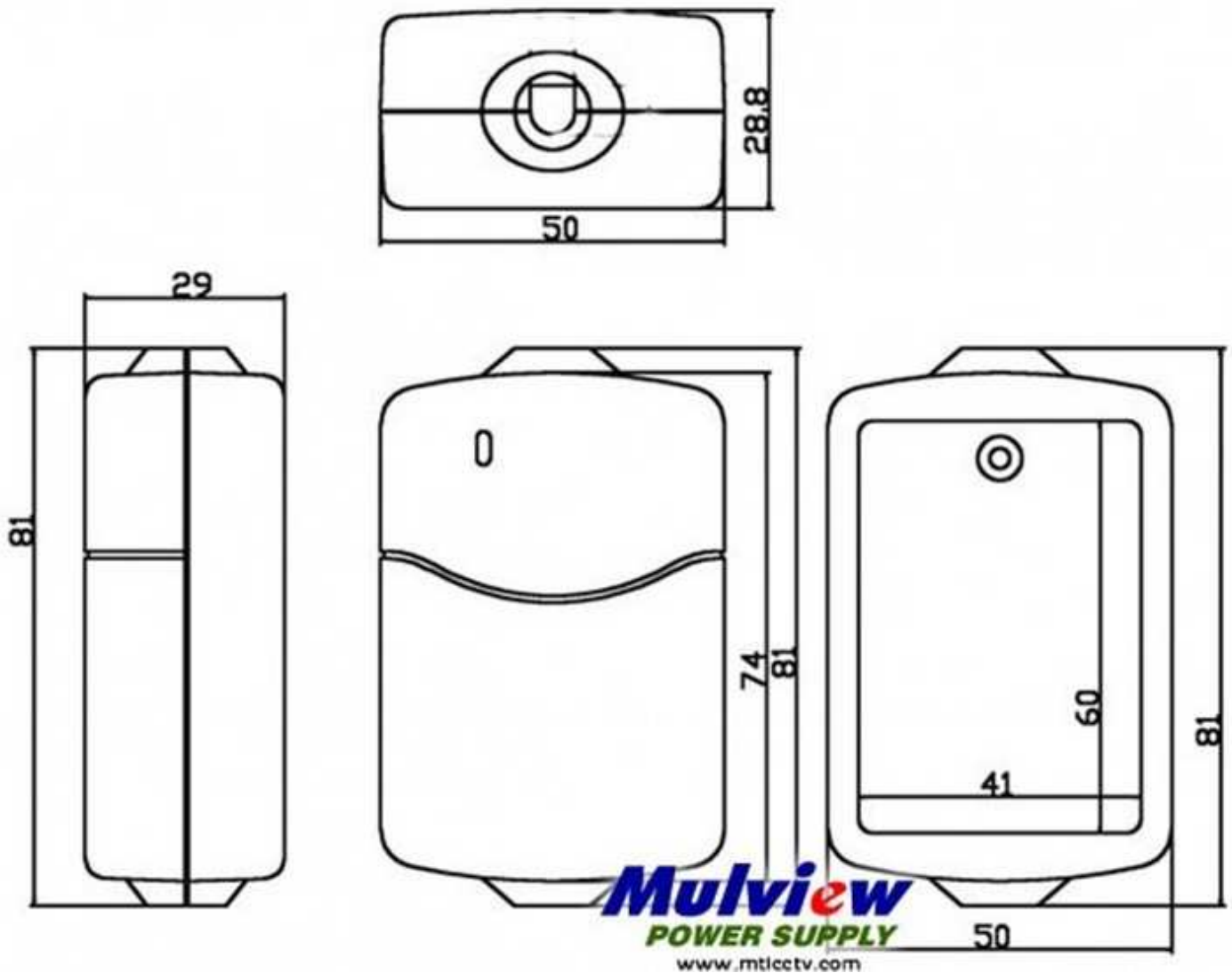

8、CORD/线材

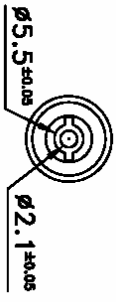
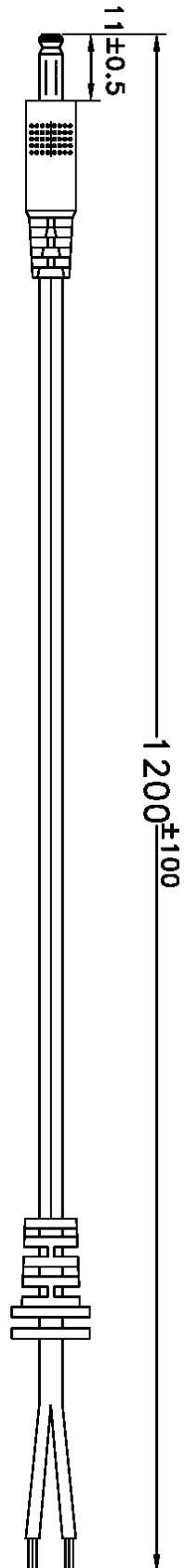

备注:

- 1.线材规格:2468 #22AWG 1.2M 80°C
- 2.PULG:5.5\*2.1\*11 音叉叉沟(镀锌黑胶)